

**COMPONENTS 2005****(PTY) LTD****t/a ENGINE & HEAVY DUTY COMPONENTS****HEAD OFFICE JOHANNESBURG**

Tel: +27 (0)11 870 5000
 Fax to Mail: 086 676 6628
 Cnr Hubert & Marshall Streets,
 Marshalltown, Johannesburg 2001
 PO Box 6541 Johannesburg, 2000,
 South Africa
 ehd@ehd.co.za

BLOEMFONTEIN

Tel: +27 (0)51 430 5404
 17 Krause Street, Oranjesig
 South Africa
 ehdbloem@ehd.co.za

CAPE TOWN

Tel: +27 (0)21 510 0567
 25 Bellray Business Park
 Ampere Street, Stikland Industrial
 Cape Town, 7530
 PO Box 1037, Milnerton, 7435
 South Africa
 ehdcapetown@ehd.co.za

DURBAN

Tel: +27 (0)31 700 1160
 Unit 3, Hillmax
 31 Hillclimb Rd, Westmead 3610
 PO Box 1054 Nagina 3604,
 South Africa
 ehd.dbn@ehd.co.za

**Y385**

Model	Y385
Type	Vertical, water-cooling, four-stroke, vortex
Number of cylinders	3
Bore (mm)	85
Stroke (mm)	90
Compression ratio	22
Total displacement	1.532
Firing order	1.-3.-2.
Rated power (kW)	19.2~24
Rated speed (r/min)	2400~3000
Max.torque (N.m)	≥84
Min.specific fuel consumption at full load (L/h)	6.1
Specific lube oil consumption (g;/kw.h)	2.72
Advance angle of supply fuel/	10±1/3000, 16±1/2600, 15±1/2400
speed (before TDC)(°)/r/min	(with Advance Device)
Injection Pressure	13.2±0.5
Direction of crankshaft rotation (facing to flywheel)	Counterclockwise
Cooling method	Forced water Cooling
Starting method	Electric
Net mass (kg)	165
Overall dimensions (LxWxH) (mm)	587x494x610

Proud Member of:



COMPONENTS 2005

(PTY) LTD

t/a ENGINE & HEAVY DUTY COMPONENTS

HEAD OFFICE JOHANNESBURG

Tel: +27 (0)11 870 5000
 Fax to Mail: 086 676 6628
 Cnr Hubert & Marshall Streets,
 Marshalltown, Johannesburg 2001
 PO Box 6541 Johannesburg, 2000,
 South Africa
 ehd@ehd.co.za

BLOEMFONTEIN

Tel: +27 (0)51 430 5404
 17 Krause Street, Oranjesig
 South Africa
 ehdbloem@ehd.co.za

CAPE TOWN

Tel: +27 (0)21 510 0567
 25 Bellray Business Park
 Ampere Street, Stikland Industrial
 Cape Town, 7530
 PO Box 1037, Milnerton, 7435
 South Africa
 ehdcapetown@ehd.co.za

DURBAN

Tel: +27 (0)31 700 1160
 Unit 3, Hillmax
 31 Hillclimb Rd, Westmead 3610
 PO Box 1054 Nagina 3604,
 South Africa
 ehd.dbn@ehd.co.za

Designation		Y385
Fuel Injection Pump	Type	I Pump
	Governor	All-speed, Mechanical Centrifugal
	Plunger Diameter (mm)	7
	Fuel Delivery Pump	Single-Acting Piston Type
Fuel Injector	Model	P21
	Nozzle Set	Single hole, Pintle-type, ZS4SI
	Diameter of Nozzle Hole(mm)	1
	Injection Pressure(Mpa)	13.2±0.5
Lube Pump	Type	Rotor
	Speed(rpm)	1300
	Capacity(L/min)	18
	Pressure(Kpa)	0.4
Water Pump	Type	Centrifugal, Volute, Single-suction
	Speed(rpm)	3000
	Capacity(L/min)	80
	Lift(m)	5
Starting Motor	Type	Series DC Motor
	Model	QD1322C,QD1315A,D138Y
	Voltage(V)	12
	Power(kW)	1.8 or 2.5
Dynamo	Type	Silicon Rectifying Shunt Dynamo
	Model	JF11
	Power(W)	350
	Voltage(V)	14
Fuel Filter	Type	Single Stage, Paper Element
	Model	C0506A
Lube Oil Filter	Type	Single Stage, Paper Element
	Model	J0708
Air Filter	Type	Single Stage, Paper Element
	Model	K1317A
Electrothermic Plug	Type	Shrouded
	Model	10/12/1965

Proud Member of:





COMPONENTS 2005

(PTY) LTD

t/a ENGINE & HEAVY DUTY COMPONENTS

HEAD OFFICE JOHANNESBURG

Tel: +27 (0)11 870 5000
Fax to Mail: 086 676 6628
Cnr Hubert & Marshall Streets,
Marshalltown, Johannesburg 2001
PO Box 6541 Johannesburg, 2000,
South Africa
ehd@ehd.co.za

BLOEMFONTEIN

Tel: +27 (0)51 430 5404
17 Krause Street, Oranjesig
South Africa
ehdbloem@ehd.co.za

CAPE TOWN

Tel: +27 (0)21 510 0567
25 Bellray Business Park
Ampere Street, Stikland Industrial
Cape Town, 7530
PO Box 1037, Milnerton, 7435
South Africa
ehdcapestown@ehd.co.za

DURBAN

Tel: +27 (0)31 700 1160
Unit 3, Hillmax
31 Hillclimb Rd, Westmead 3610
PO Box 1054 Nagina 3604,
South Africa
ehd.dbn@ehd.co.za

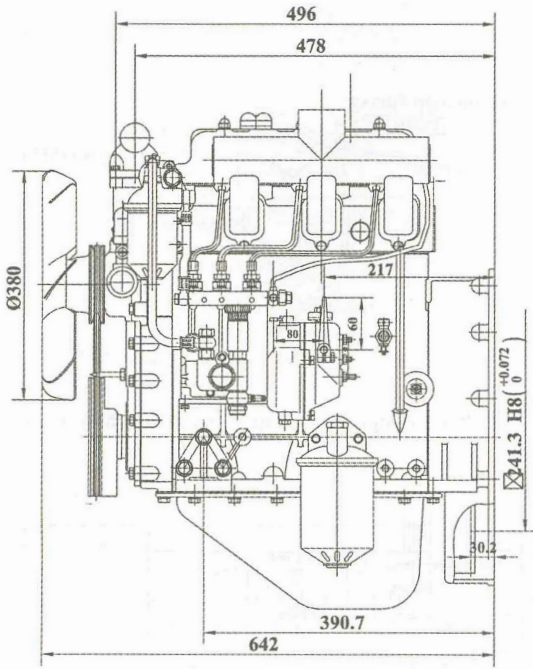

Connecting dimensions of flywheel and its housing

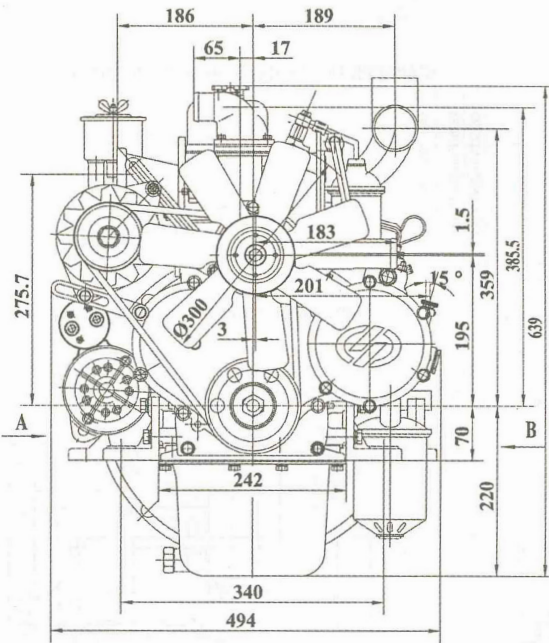
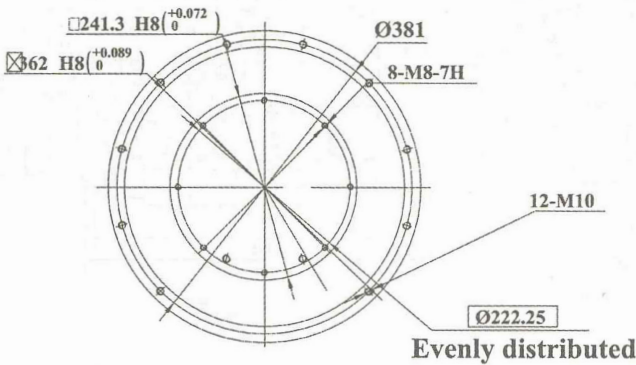

Dimensions of water inlet and outlet

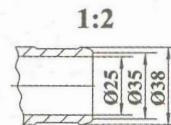

Flywheelhousing/flywheel:SAE4/7.5

View A(cylinder block)

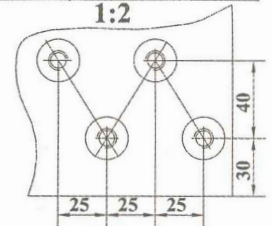

View B(cylinder block)

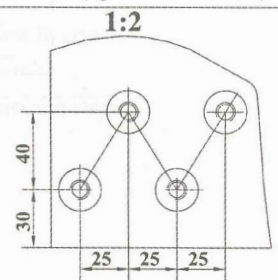

Dimensions of exhaust outlet

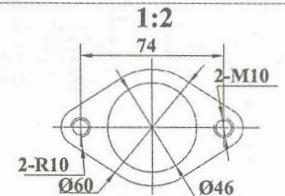

Proud Member of:

